

March 1974

ILLUSTRATED PRICE LIST

PLEASE NOTE:

New Hermes **Bench Type** machines are delivered fully equipped — ready for immediate operation. Vital accessories which are normally sold as extras are included as standard equipment, such as:

- Automatic depth regulator with micrometer adjustment.
- Self-centering workholding fixture with interchangeable jigs.
- Carbide tipped engraving cutter.

FREE DELIVERY within the continental U.S. if order is accompanied by check.

new hermes engravograph®

Representative:

MR. JACK DOMITO

new hermes ENGRAVING MACHINE CORP.

P. O. Box 1677 San Mateo, Calif. 94401

Telephone: (415) 347-6966

new hermes engraving machine corporation

20 COOPER SQUARE (3rd AVENUE & 5th STREET)
NEW YORK, N. Y. 10003 TEL.: (212) 777-3080

SOUTHEAST

2620 Park Central Blvd.
Decatur, Ga. 30032
(404) 981-2563

MIDWEST

3534 W. 63rd St.
Chicago, Ill. 60629
(312) 778-5352

SOUTHWEST

12243 E. Northwest Hwy.
Dallas, Texas 75228
(214) 328-8131

WEST COAST

4665 Melrose Ave.
Los Angeles, Cal. 90029
(213) 665-4141

CANADA

323 Benjamin Hudon Street
Montreal 379, Quebec
(514) 334-1780

3320 Elmbank Road
Malton, Ontario
(416) 677-2224

REPRESENTATIVES IN ALL PRINCIPAL CITIES

MODEL I-M

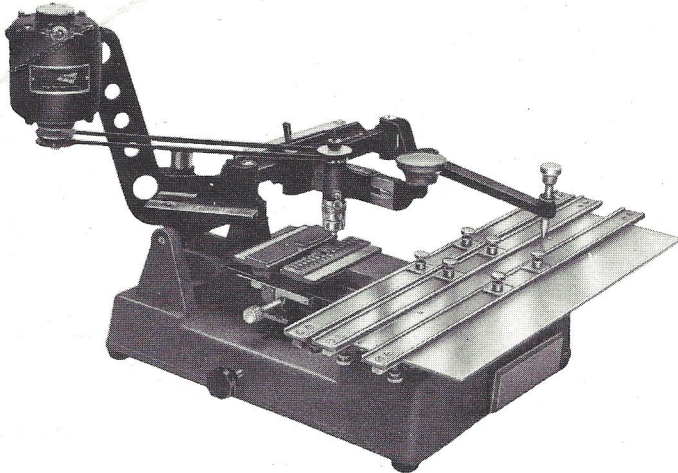

Multi-ratio pantograph, adjustable from 2½:1 to 7:1

Engraving spindle with shielded ball bearings for ⅜" diameter cutters

Graduated copy table 6" x 16"

Depth regulator with micrometer adjustment

Regulator nose, Part #30-303-00

Universal self-centering vise with interchangeable 6" holding jigs

Carbide tipped cutter, Part #40 307, .030 wide

*Universal motor with preloaded ball bearings, 115 volts

Rubberized endless motor belt
Belt guard

Cutter head wrench

Sample roll of double faced tape

Cleaning brush

Instruction booklet

Accessory drawer

Allen wrench

Dust cover

**3 individually adjustable copy holding slides 18" long for ⅝" or 1¼" master copy blanks with 6 end stops and 3 centering scales

MODEL I-L II

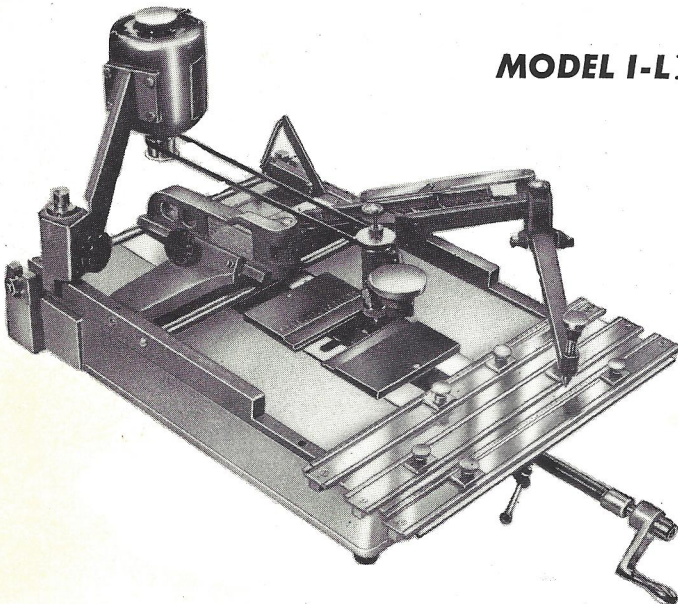

Multi-ratio pantograph, adjustable from 2½:1 to 7:1

Engraving spindle with shielded ball bearings for ⅜" diameter cutters

Graduated copy table 4½" x 16"

Depth regulator with micrometer adjustment

Regulator nose, Part #30-303-00

Self-centering nameplate holder with double acting spindle and holding jigs

Carbide tipped cutter, Part #40 307, .030 wide

*Universal motor with preloaded ball bearings, 115 volts

Rubberized endless motor belt
Belt guard

Cutter head wrench

Sample roll of double faced tape

Cleaning brush

Instruction booklet

Accessory box

Dust cover

**3 individually adjustable copy holding slides 18" long for ⅝" or 1¼" master copy blanks with 6 end stops and 3 centering scales

MODEL I-Lk II

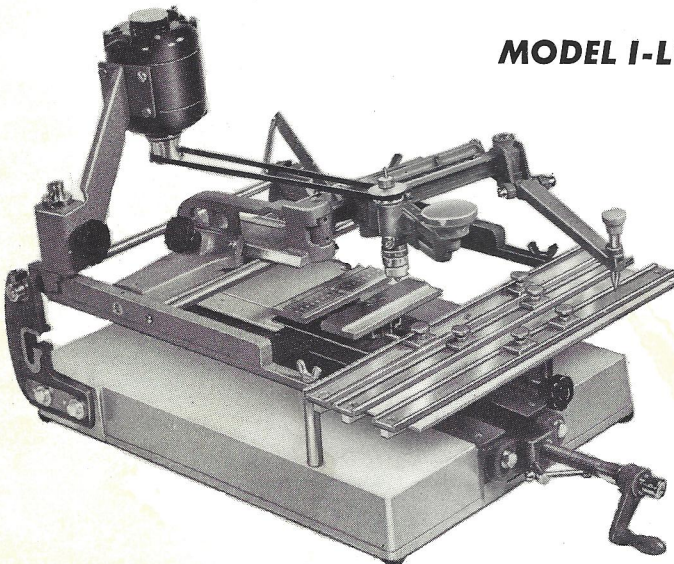

Multi-ratio pantograph, adjustable from 2½:1 to 7:1

Engraving spindle with shielded ball bearings for ⅜" diameter cutters

Graduated copy table 4½" x 16"

Depth regulator with micrometer adjustment

Regulator nose, Part #30-303-00

Self-centering nameplate holder with double acting spindle and holding jigs

Universal self-centering vise K-1 with interchangeable 6" holding jigs

Carbide tipped cutter, Part #40 307, .030 wide

*Universal motor with preloaded ball bearings, 115 volts

Rubberized endless motor belt
Belt guard

Cutter head wrench

Sample roll of double faced tape

Cleaning brush

Instruction booklet

Accessory box

Dust cover

**3 individually adjustable copy holding slides 18" long for ⅝" or 1¼" master copy blanks with 6 end stops and 3 centering scales

Accessories for Models I-L, I-Lk, I-M

ENGRAVING CUTTERS

1/8" Shank Precision Ground

Engraving Material	High Speed Steel	Solid Carbide
PHENOLICS		40 304
GRAVOPLY		40 307
GRAVOFLEX		40 316
ACRYLICS	40 327	
FERROUS METAL	40 324	40 306
ALUMINUM BRASS		40 308
MASTER	40 323	40 302
STENCIL	40 322	40 301
Prices:		
2 Cutters	\$ 7.00	\$14.00
6 Assorted	18.00	39.00

For parallel cutters add 50%

CUTTER ASSORTMENT

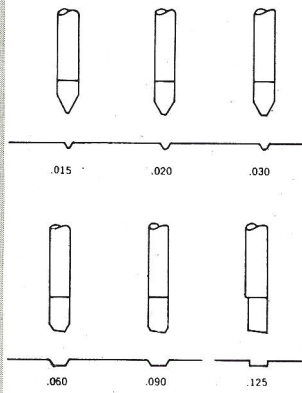

or any combination of 6.
Intermediate widths available.

COPY HOLDING SLIDES

(With 2 End Stops and Centering Scale)

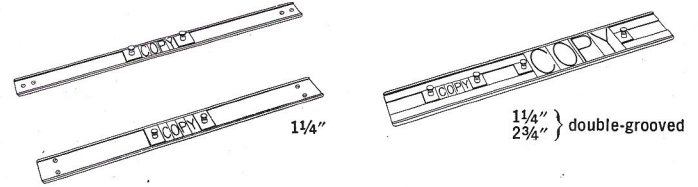

Length of Slide	Blank Size	Model I-L Model I-Lk	Model I-L II Model I-Lk II	Model I-M	Prices
13 1/2"	5/8"	33 031 00			\$15.00
18"	5/8"	33 041 00	33 045 00	33 045 00	20.00
	1 1/4"	33 141 00	33 145 00	33 145 00	20.00
22"	1 1/4"	33 251 00	33 255 00	33 255 00	35.00
	2 3/4"				
26"	1 1/4"		33 165 00	33 165 00	30.00
	1 1/4"	33 261 00	33 265 00	33 265 00	40.00

Centering Scales for Above Slides, see page 11.

END STOPS FOR ABOVE SLIDES

Part No.
33 521 00 for 5/8" slide
33 524 00 for 1 1/4" slide
33 527 00 for double-grooved slide
Pair \$5.00
3 Pair \$10.00



SECTIONAL VERTICAL SLIDES (With 2 End Stops)

	For Blanks	Price
33 000 00	5/8"	\$10.00

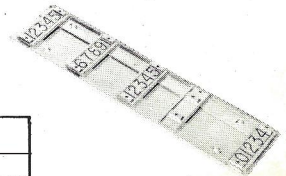

HOLDING JIGS

For Universal Vise

Models I-M and IL-K

30 767 00 6" long pr. \$12.50
30 774 00 8" long pr. \$15.00

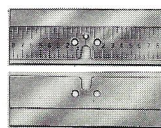

With adjustable positioning stop:

30 777 00 6" long pr. 13.50
30 778 00 8" long pr. 15.00

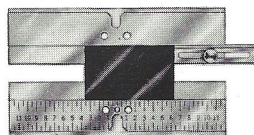

For Holding Jigs on Machine Base

Models I-L and IL-K

30 761 00 4" long pr. 10.00



For Holding Jigs on Machine Base

For Badges with alligator and snap clips attached:

30 712 40 3" long pr. 15.00



COPY SLIDE CONVERTER (With 2 End Stops)

Converts double-grooved holding slide to accept two lines of 1 1/4" blanks.

Part No. 33 350 00 22" long \$15.00
Part No. 33 360 00 26" long 20.00

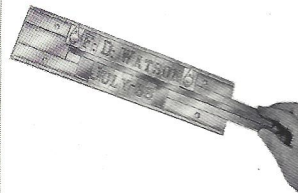

MOTOR BELTS (set of 3)

30 215 00 23" long set \$5.00



IMPORTANT:

When ordering parts please remember:

1. There is a minimum charge of \$15.00 per shipment. Save by combining order to meet minimum.
2. Use part numbers for quicker identification.
3. Give serial number of machine.

MODEL ITF II

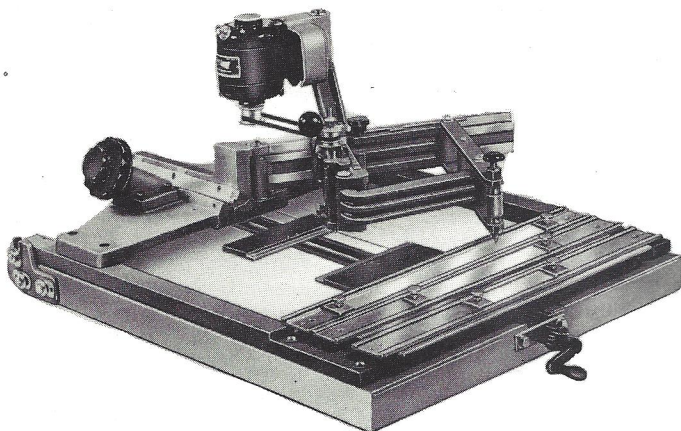

Multi-ratio pantograph, (heavy duty) adjustable from 2:1 to 7:1
Engraving spindle with shielded ball bearings for 11/64" diameter cutters
Graduated copy table 6" x 16"
Depth regulator with micrometer adjustment
Regulator nose, Part #30-303-00
Self-centering nameplate holder with double acting spindle and holding jigs
Carbide tipped cutter, Part #42 007, .030 wide

*Universal motor with preloaded ball bearings, 115 volts
Rubberized endless motor belt 15"
Belt guard
Cutter head wrench
Sample roll of double faced tape
Cleaning brush
Instruction booklet
Accessory box
Allen wrench
Dust cover

**3 individually adjustable copy holding slides 18" long for 5/8" or 1 1/4" master copy blanks with 6 end stops and 3 centering scales

MODEL ITF-K II

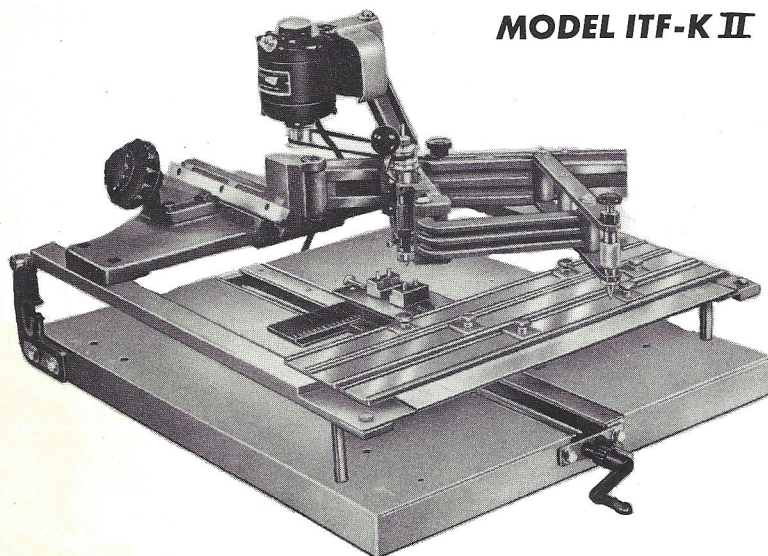

Multi-ratio pantograph, (heavy duty) adjustable from 2:1 to 7:1
Engraving spindle with shielded ball bearings for 11/64" diameter cutters
Graduated copy table 6" x 16"
Depth regulator with micrometer adjustment
Regulator nose, Part #30-303-00
Universal self-centering vise K-1 with interchangeable 6" holding jigs
Self-centering nameplate holder with double acting spindle and holding jigs

Carbide tipped cutter, Part #42 007, .030 wide
*Universal motor with preloaded ball bearings, 115 volts
Rubberized endless motor belt 15"
Belt guard
Cutter head wrench
Sample roll of double faced tape
Cleaning brush
Instruction booklet
Accessory box
Allen wrench
Dust cover

**3 individually adjustable copy holding slides 18" long for 5/8" or 1 1/4" master copy blanks with 6 end stops and 3 centering scales

MODEL ITX

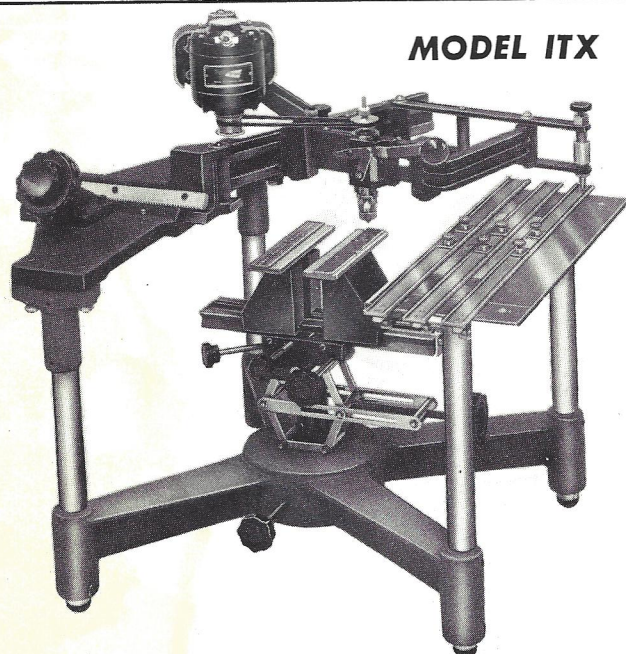

Multi-ratio pantograph, (heavy duty) adjustable from 2:1 to 7:1
Engraving spindle with shielded ball bearings for 11/64" diameter cutters
Graduated copy table 6" x 16"
Depth regulator with micrometer adjustment
Regulator nose, Part #30-303-00
Heavy duty Universal self-centering vise SC-1 with 1 pair of 6" and 1 pair of 12" holding jigs
Scissor jack
Carbide tipped cutter, Part # 42 007, .030 wide

*Universal motor with preloaded ball bearings, 115 volts
Rubberized endless motor belt 15"
Belt guard
Cutter head wrench
Sample roll of double faced tape
Cleaning brush
Instruction booklet
Accessory box
Allen wrench
Dust cover

**3 individually adjustable copy holding slides 18" long for 5/8" or 1 1/4" master copy blanks with 6 end stops and 3 centering scales

With extra large workholder #SC-3 (Illustrated on next page) substituted for standard workholder #SC-1

Accessories for Models ITF, ITF-K, ITX

ENGRAVING CUTTERS

11/64" Shank Precision Ground

Engraving Material	High Speed Steel	Carbide Tipped
PHENOLICS		42 004
GRAVOPLY		42 007
GRAVOFLEX		42 016
ACRYLICS	42 027	
FERROUS METAL	42 024	42 006
ALUMINUM } BRASS }		42 008
MASTERS	42 023	42 002
STENCILS	42 022	42 001
Prices:		
2 Cutters	\$ 8.50	\$17.00
6 Assorted	22.50	48.00

For parallel cutters add 50%

CUTTER ASSORTMENT

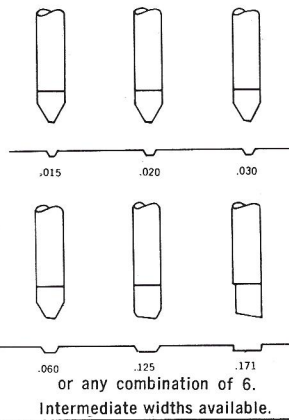

COPY HOLDING SLIDES

(With 2 End Stops and Centering Scale)

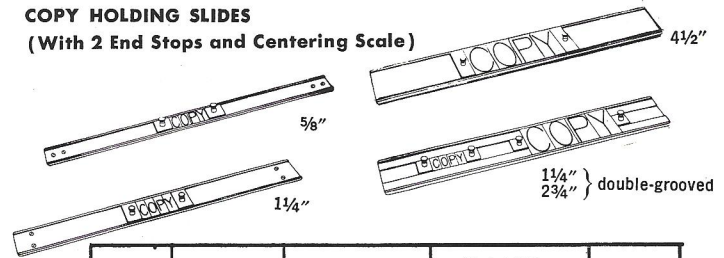

Length of Slide	Blank Size	Model ITX	Model ITF Model ITF-K	Prices
18"	5/8"	33 045 00	33 042 00	\$20.00
	1 1/4"	33 145 00	33 142 00	20.00
22"	1 1/4" } 2 3/4" }	33 255 00	33 252 00	35.00
	5/8"	33 065 00	33 062 00	30.00
26"	1 1/4"	33 165 00	33 162 00	30.00
	1 1/4" } 2 3/4" }	33 265 00	33 262 00	40.00
36"	5/8"	33 075 00	33 072 00	40.00
	1 1/4"	33 175 00	33 172 00	40.00
	1 1/4" } 2 3/4" }	33 275 00	33 272 00	55.00
	4 1/2"	33 475 00	33 472 00	55.00

Centering Scales for Above Slides, see page 11.

END STOPS FOR ABOVE SLIDES

Part No.

33 521 00 for 5/8" slide
33 524 00 for 1 1/4" slide

33 527 00 for double-grooved slide
33 534 00 for 4 1/2" slide

Pair \$5.00
3 Pair \$10.00

DIAMOND GRAVER—Non-Rotating

For hardened surfaces

Part No. 42 036

\$17.50



TRACING STYLUS—Carbide-Tipped

Part No. 58 640 30

\$15.00



NOSES FOR DEPTH REGULATOR

Part No.

30 300 00 clearance hole .040 for cutters to .020
30 301 00 " " .060 " " to .040
30 302 00 " " .093 " " to .060
30 303 00 " " .187 " " to .171
ea. **\$5.00**

Boxed assortment of 4 **\$15.00**

30 313 00 clearance hole .312 for very wide cuts with special retaining nut **\$6.00**

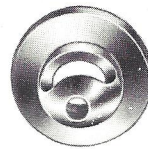

HOLDING JIGS

For Universal Vise

Model ITF-K

30 767 00 6" long

pr. **\$12.50**

30 774 00 8" long

pr. **13.50**

Model ITX

30 767 00 6" long

pr. **12.50**

30 774 00 8" long

pr. **13.50**

30 724 00 12" long

pr. **15.00**

With adjustable positioning stop:

Model ITF-K

30 777 00 6" long

pr. **13.50**

30 778 00 8" long

pr. **15.00**

Model ITX

30 777 00 6" long

pr. **13.50**

30 778 00 8" long

pr. **15.00**

30 730 00 12" long

pr. **17.50**

For Holding Jigs on Machine Base

Model ITF & ITF-K

For machines with numbers up to 75811

30 752 00 6" long pr. **\$10.00**

For machines starting with number 76000 & up

30 752 37 pr. **\$10.00**

For Badges with alligator and snap clips attached:

Model ITF

30 712 40 3" long

pr. **\$15.00**

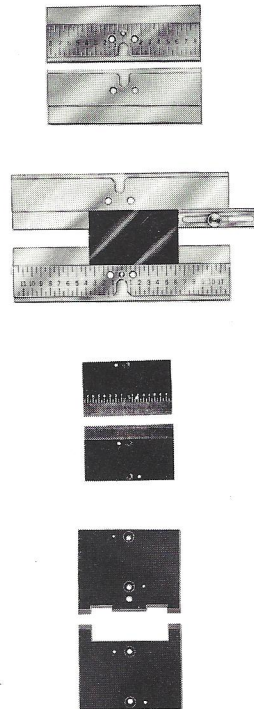

COPY SLIDE CONVERTER (With 2 End Stops)

Converts double-grooved holding slide to accept two lines of 1 1/4" blanks.

Part No. 33 350 00 22" long **\$15.00**

Part No. 33 360 00 26" long **20.00**

Part No. 33 370 00 36" long **25.00**

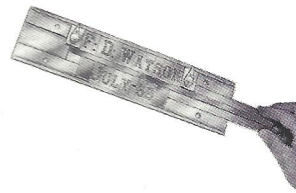

MOTOR BELTS (set of 3)

30 215 00 23" long

30 213 00 15" long

set **\$5.00**



MACHINE STAND FOR MODEL ITX (includes two storage shelves)

A sturdy, space saving stand which takes away all the strain from standing or stooping. Allows operation of the machine in a comfortable sitting position. Equipped with two shelves for extra storage space.

30 360 00 **\$25.00**

30 370 00 2 adjustable swivel trays **\$12.50**



SC-3 UNIVERSAL WORKHOLDER { Part No. 66 300 03 for Model I-TX Part No. 66 300 04 for Model VB

Designed for clamping large panels up to 16" wide and tubular objects up to 6" in diameter by 16" long. Gear arrangement facilitates turning tubes during engraving operation. The entire unit can be moved back, forth and laterally. It can also be swiveled around for engraving in any position. **Specifications:** Maximum opening of jaws 1 1/2"; Height of jaws 4 1/8"; Width of jaws 3"; Longitudinal travel 22"; Traverse travel 3 1/8".

Includes: 2 pair of jigs, wooden cones **\$250.00**
with scissor jack, Part No. 30 380 00 **\$275.00**

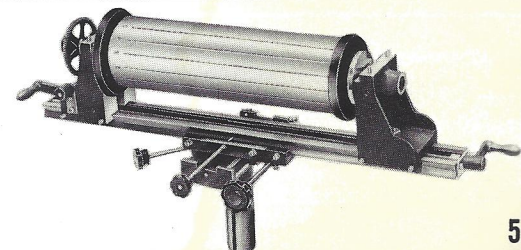

Bench Type

WITH THE FOLLOWING
STANDARD EQUIPMENT

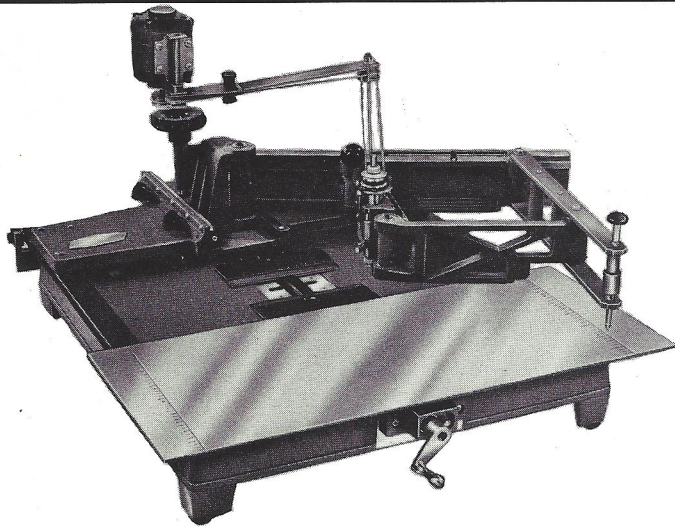

MODEL IRX-III

Multi-ratio pantograph (heavy duty) adjustable from 2:1 to 8:1
Engraving spindle with shielded ball bearings for 1/4" diameter cutters
Graduated copy table, 24" x 10"
Depth regulator with micrometer adjustment and regulator nose
Self-centering nameplate holder with double acting spindle and holding jigs
Carbide tipped cutter, Part #43 007, .030 wide
*Universal motor with preloaded ball bearings, 115 volts

2 endless motor belts Part #55 536 00
Cutter head wrench
Sample roll of double faced tape
Cleaning brush
Instruction booklet
Accessory box
Hex key
Allen wrench
Dust cover

*220 volt motor can be supplied

Accessories

ENGRAVING CUTTERS

1/4" Shank Precision Ground

Engraving Material	High Speed Steel	Carbide Tipped
PHENOLICS		43 004
GRAVOPLY		43 007
GRAVOFLEX		43 016
ACRYLICS	43 027	
FERROUS METALS	43 024	43 006
ALUMINUM)		43 008
BRASS)		
MASTERS	43 023	43 002
STENCILS	43 022	43 001
Prices:		
2 Cutters	\$ 8.50	\$17.00
6 Assorted	22.50	48.00

For parallel cutters add 50%

CUTTER ASSORTMENT

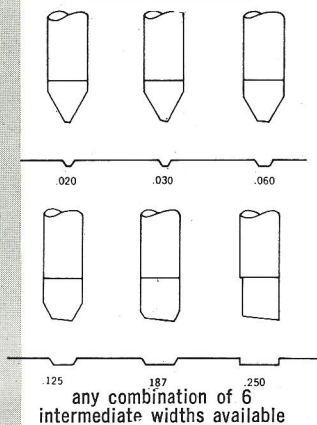

COPY HOLDING SLIDES

(With 2 End Stops and Centering Scale)

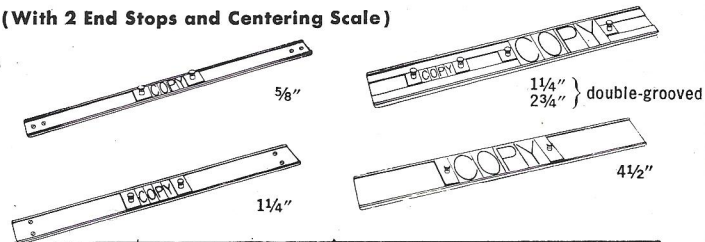

Length of Slide	Blank Size	Model IRX	Prices
26"	5/8"	33 064 00	\$30.00
	1 1/4"	33 164 00	30.00
	1 1/4" } 2 3/4" }	33 264 00	40.00
36"	5/8"	33 074 00	40.00
	1 1/4"	33 174 00	40.00
	1 1/4" } 2 3/4" }	33 274 00	55.00
	4 1/2"	33 474 00	55.00

Centering Scales for Above Slides, see page 11.

END STOPS FOR ABOVE SLIDES

Part No.
33 521 00 for 5/8" slide
33 524 00 for 1 1/4" slide
33 527 00 for double-grooved slide
33 534 00 for 4 1/2" slide
Pair \$5.00
3 Pair \$10.00

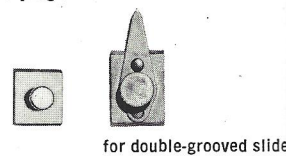

DIAMOND GRAVER—Non-Rotating

For hardened surfaces
Part No. 43 036 \$17.50



TRACING STYLUS

Part No. 55 646 30 Hardened tool steel 5.00
Part No. 55 647 33 Carbide tipped 15.00



NOSES FOR DEPTH REGULATOR

30 310 00 clearance hole .093 for cutters to .060
30 311 00 " " .187 " " to .125
30 312 00 " " .250 " " to .187
30 313 00 " " .312 " " to .250
ea. \$5.00

Boxed assortment of 4 \$15.00



MOTOR BELTS

55 536 00 for machines with Idler Arm Assembly.
set of 2 \$5.00

30 216 00 for Models I-R or IRX-II beginning with
serial No. 275,000 up to No. 275,556.
27" long set of 3 \$5.00

30 215 00 for Model I-RX 23" long
set of 3 \$5.00



HOLDING JIGS

For nameplates
Part No. 30 752 00 6" long pr. 10.00

For Badges with alligator and snap
clips attached:
30 712 40 3" long pr. 15.00

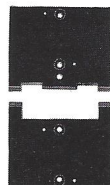

COPY SLIDE CONVERTER

(With 2 End Stops)

Converts double-grooved holding slide to
accept two lines of 1 1/4" blanks.

Part No. 33 360 00 26" long 20.00
Part No. 33 370 00 36" long 25.00

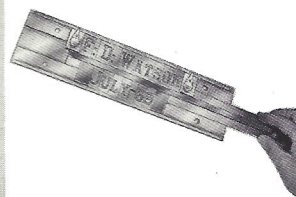

FOOT SWITCH

Can be used with all Engravographs.
Part No. 31 081 00 \$12.00



Cutter Grinder Model CG-4

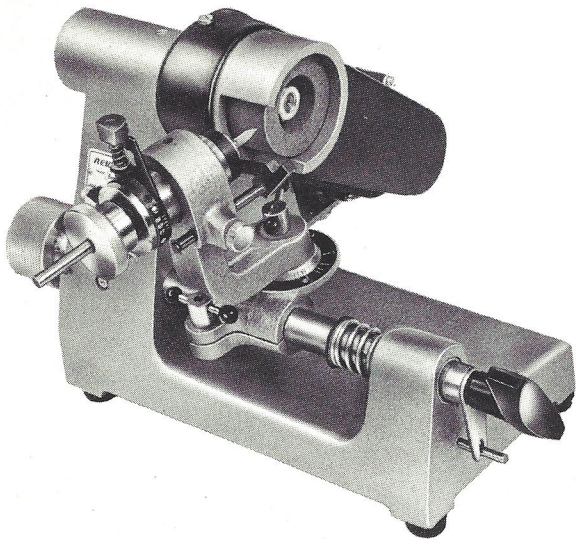

belt-driven with precision ball bearing spindle

*Universal motor with preloaded ball bearings, 115 volts

Tool head with indexing device

Grinding wheel, 30 271 00

**Collet for 1/8", 1/16", 1/4", or 5/16" cutters

Diamond dresser

Endless motor belt

Socket spindle wrench

Spindle lock pin

Instruction booklet

**specify collet size required

*220 volt motor available



GRINDING WHEELS

Part No.

30 272 00 2 1/4" silicon carbide wheel for rough grinding of carbide cutters Set of 2 \$6.00

30 273 00 2 1/4" resin bound diamond wheel for carbide cutters \$95.00

30 271 00 2 1/4" grinding wheel for high speed steel cutters Set of 2 \$6.00



GRINDER COLLETS

Part No.

30 236 00 spring collet for 1/8" cutters

30 237 00 " " " 1/16" " "

30 238 00 " " " 3/16" " "

30 239 00 " " " 1/4" " "

30 240 00 " " " 5/16" " "

ea. \$15.00

Part No. 30-241 taper shank adapter 15.00
(to be used with 5/16" collet)



DIAMOND DRESSER

Part No.

30 274 00 for 1/8" collet

30 275 00 " 1/16" "

30 276 00 " 1/4" "

30 277 00 " 5/16" "

ea. \$15.00

Beveler Model B-4

WITH THE FOLLOWING STANDARD EQUIPMENT

*Universal motor with pre-loaded ball bearings, 115 volts

Endless motor belt

Cutter spindle with shielded ball bearings & adjustment for depth

Carbide tipped beveling cutter, 45°

*220 volt motor available



BEVEL AND BORDER CUTTERS

1/8" Diameter — Carbide Tipped
Precision ground

Part No.

40 510 bevel cutter 30° angle

40 511 bevel cutter 45° angle

40 512 border cutter for all border widths from 1/32" up to 1/8"

2 for \$14.00

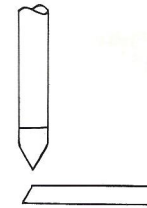

30°



45°

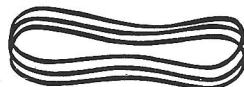

For Cutter Grinder
MOTOR BELTS (set of 3)

30 214 00 17 1/16" long set \$5.00

For Beveler
MOTOR BELTS (set of 3)

30 211 00 9 1/2" long (for B-2, B-3 & B-4)
30 213 00 15" long (for B-1) set \$5.00

IMPORTANT:

When ordering parts please remember:

1. There is a minimum charge of \$15.00 per shipment. Save by combining order to meet minimum.
2. Use part numbers for quicker identification.
3. Give serial number of machine.

MODEL VB-III

Pantograph assembly with precision ball bearings on all joints
Ratio settings 1:1 to 100:1

Heavy duty cutter spindle with precision ball bearings
with collet for 5/16" straight shank cutters
and micrometer adjustment for depth

Compound table with longitudinal travel 9 5/8"
and transverse travel 7 3/8"

*Motor with precision ball bearings for
continuous duty 1/5 H.P. A.C. 3450 RPM

Endless motor belts

2 T bolts with straps 3" long

2 T bolts with straps 5" long

2 high speed steel engraving cutters

Graduated copy table 24" x 10"

Set of wrenches

Sample roll of double faced tape

Accessory box

Cleaning brush

Instruction booklet

Dust cover

*220 volt motor can be supplied.

CABINET BENCH

Heavy gauge steel complete with storage shelf for type boxes and
storage bin for accessories.

Part No. 30 364 00

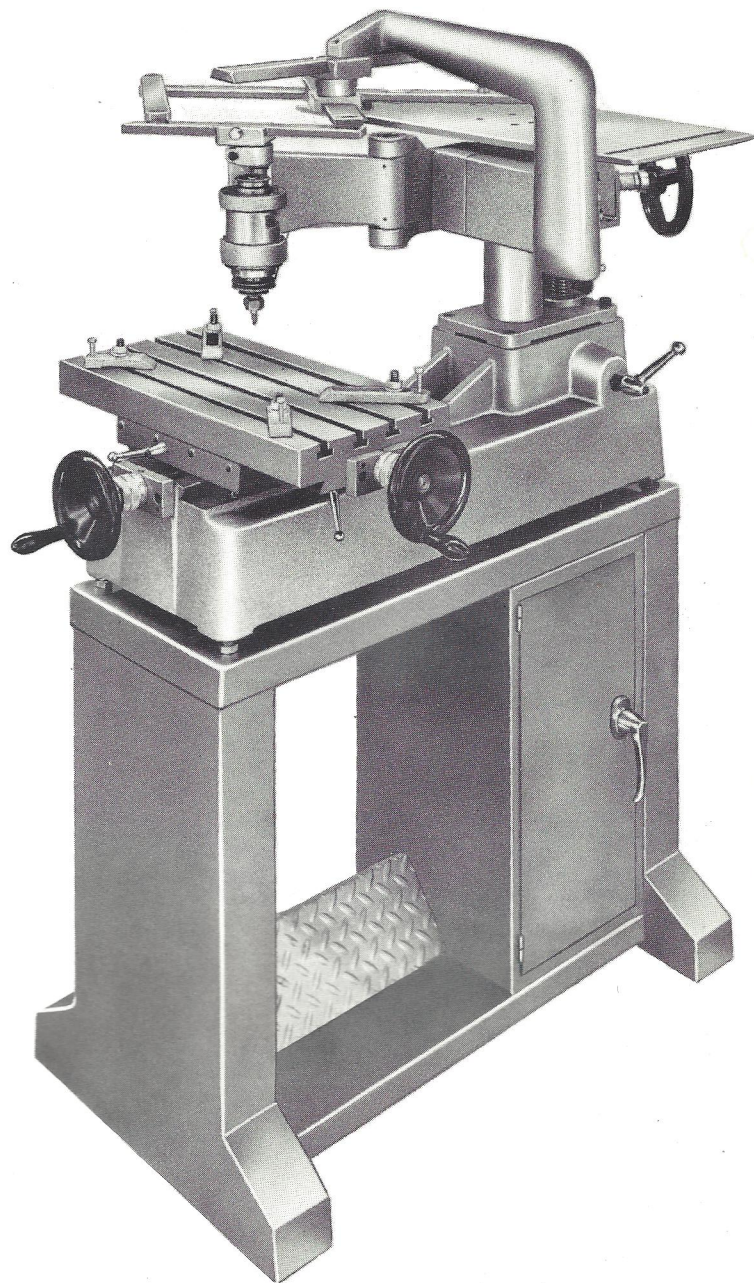

Model VB-III is available with a pneumatic attachment which consists of:

Air cylinder, Regulator with pressure gauge, Feed regulator, Air hose ready to be connected to any compressor, Jacobs chuck with key for drills up to 3/8" add \$175.00

Accessories for Model VB

ENGRAVING CUTTERS

5/16" Straight Shank. Precision Ground

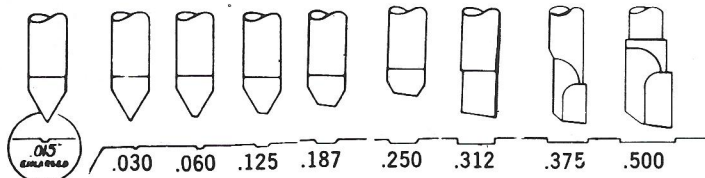

Intermediate widths available
(add'l information on back page)

State cutting width desired

Engraving Material	High Speed Steel	Carbide Tipped	Carbide tipped for extra wide cut on plastics
PHENOLICS		44 105	44 215 3/8" width with 1/4" shank
GRAVOPLY		44 107	
GRAVOFLEX		44 116	44 315 1/2" width with 1/4" shank
ACRYLICS	44 127		
FERROUS METALS	44 124	44 106	
ALUMINUM } BRASS }		44 108	
MASTER	44 123	44 102	
STENCIL	44 122	44 101	

Prices: 2 for \$7.00 2 for \$17.00 \$15.00 each

For parallel cutters, add 50%

DIAMOND GRAVER

Non-rotating for diamond drag on hardened surfaces Part No. 44 136 \$15.00

NOSES FOR DEPTH REGULATOR

Part No.

30 310 00 clearance hole .093 for cutters to .060
30 311 00 " " .187 " " to .125
30 312 00 " " .250 " " to .187
30 313 00 " " .312 " " to .250
ea. \$5.00

Boxed assortment of 4 \$15.00



COLLETS

30 252 00 for 1/8" diameter cutters
30 253 00 " 3/16" " "
30 254 00 " 1/4" " "
30 255 00 " 5/16" " " ea. \$15.00

Part No. 30-241 taper shank adapter 15.00
(to be used with 5/16" collet)

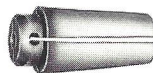

DEPTH REGULATOR

With depth regulator nose
for Models VB and VB-II:

Part No. 61 800 00 \$39.00

for Model VB-III:

Part No. 61 800 25 \$39.00

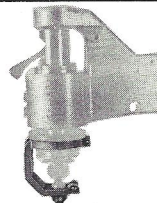

TRACING STYLUS

61 474 41 Hardened tool steel \$ 5.00
61 474 46 Carbide tipped 15.00



IMPORTANT:

When ordering parts please remember:

1. There is a minimum charge of \$15.00 per shipment. Save by combining order to meet minimum.
2. Use part numbers for quicker identification.
3. Give serial number of machine.

For Model VB only:

SC-1 UNIVERSAL SELF-CENTERING VISE WITH INTERCHANGEABLE HOLDING JIGS

Maximum opening of jaws 7"
Height of jaws 3"
Width of jaws 3"
Longitudinal travel 7 1/4"
Traverse travel 2 1/2"

Part No. 06 100 04 \$150.00

For larger capacity with jaw opening to 19 1/2", see Universal Workholder SC-3, Part No. 66 300 04 on page 5. \$250.00

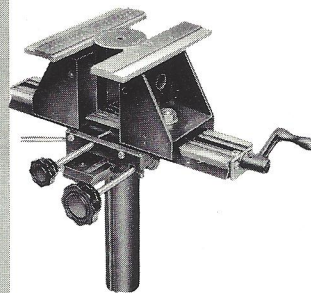

For Models VB-II and VB-III only:

SC-1 UNIVERSAL SELF-CENTERING VISE WITH INTERCHANGEABLE HOLDING JIGS

Maximum opening of jaws 7"
Height of jaws 3"
Width of jaws 3"

Part No. 66 102 25 \$150.00

For larger capacity with jaw opening to 19 1/2", see Universal Workholder SC-3, Part No. 66 300 05 on page 5. \$250.00

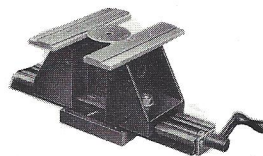

COPY HOLDING SLIDES (With 2 End Stops)

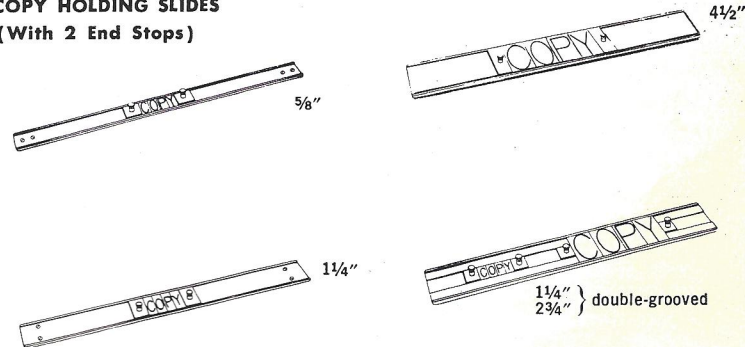

Length of Slide	Blank Size	Model VB	Prices
26"	5/8"	33-066 00	\$30.00
	1 1/4"	33 166 00	30.00
	1 1/4" } 2 3/4" }	33 266 00	40.00
36"	1 1/4" } 2 3/4" }	33 276 00	55.00
	4 1/2"	33 476 00	55.00

Centering Scales for Above Slides, see page 11.

END STOPS FOR ABOVE SLIDES

Part No.
33 521 00 for 5/8" slide
33 524 00 for 1 1/4" slide
33 527 00 for double-grooved slide
33 534 00 for 4 1/2" slide

Pair \$5.00
3 Pair \$10.00

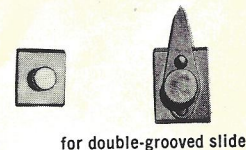

for double-grooved slide



T BOLTS WITH STRAPS

Part No. 61 870 00 3" long
Part No. 61 880 00 5" long

pr. \$10.00



MOTOR BELTS

Part No. 61 830 00

2 for \$5.00

Multi-Spindle

For engraving up to 6 objects simultaneously in one operation.

This time saving production machine is available with quick clamping self-centering work-holders for manual operation or pneumatic vises for automatic clamping.

We suggest that you let us have samples of your engraving requirements so that our Engineering Department can suggest the most suitable equipment.

Ball bearing pantograph with ratio settings from 2:1 to 6:1

Stainless steel copy table with graduated setup scales

3 adjustable copy holding slides 18" long, for $\frac{5}{8}$ " master blanks

or

for $\frac{1}{4}$ " master blanks

Complete pneumatic equipment with feed control, air cylinder, regulator with pressure gauge, air hoses, with ready connection for: 6 pneumatically operated ball bearing cutter spindles for $\frac{11}{64}$ " diameter cutters

6 universal self-centering clamping vises, adjustable for longitudinal and traverse travel, maximum opening $4\frac{7}{8}$ "

6 pair of interchangeable holding jigs, Part No. 30 725 00

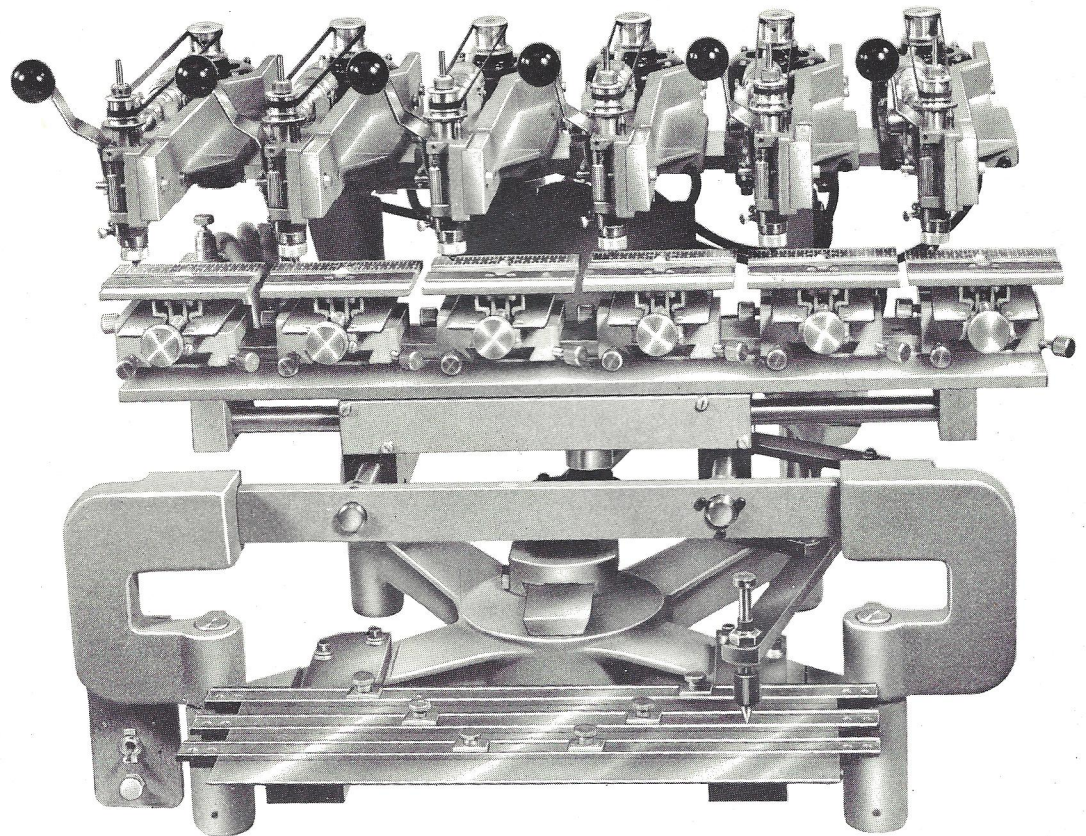

Although the illustrated machine is equipped with 6 motor driven spindles, it can also be ordered as a 3, 4 or 5 spindle unit.

In that case, a credit of **\$250.00** per unit can be given.

Complete **\$4,800.00**

Combination Seal — Nameplate Engraver

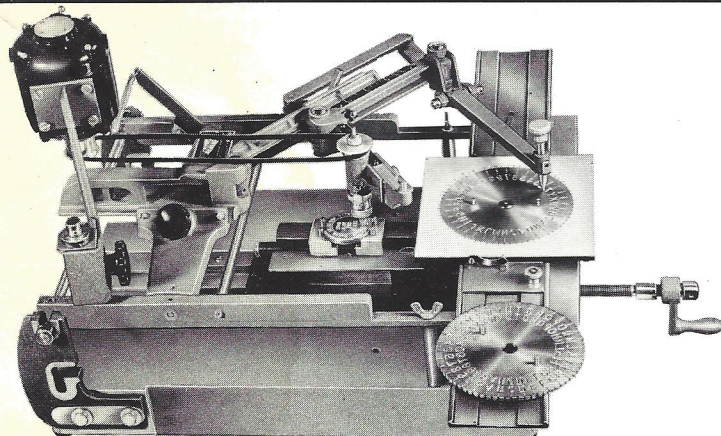

MODEL I-Lk II equipped for seal engraving

INCLUDES

Multi-ratio pantograph, adjustable from $2\frac{1}{2}$:1 to 6:1

Graduated copy table $4\frac{1}{2}$ " x 16"

1 double grooved slide for $1\frac{1}{4}$ " and $2\frac{3}{4}$ " master copy blanks

Self centering nameplate holder with double acting spindle

1 Seal Indexing Fixture, Part #35 255 00, consisting of 2 dials, with 45 characters in each, for $1\frac{5}{8}$ ", $1\frac{1}{4}$ " and 2" diameter seals

Universal motor with preloaded ball bearings, 115 volts

2 High speed steel cutters

Sample roll of double faced tape

For spare parts and accessories, see listings under Model I-L.

Supplementary Material for Every Engraving Department

ENGRAVER'S ENAMEL



Especially made for filling engraved surfaces with contrasting colors. It can be used on all engravings in metal, plastic, mother-of-pearl, etc. The porcelain-like finish dries hard rapidly and gives the engraved letter a high gloss.

Black	Medium Green
Brilliant Blue	Medium Orange
Fire Red	White
Lemon Yellow	Bright Gold

Available in 1/2 pint cans only. 4 cans to a carton in any color combination.
Part No. 30 450 00 per ctn. **\$15.00**

ENGRAVOCOLOR STICK (For Plastic Only)



White	Green	Yellow
Red	Blue	Silver
Black	Gold	

Packed a dozen assorted colors to a carton.
Part No. 30 465 00 per ctn. **\$6.00**

DOUBLE FACED ADHESIVE TAPE

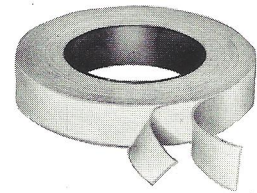

For attaching individual master copy type whenever layout requires. 25 yards by 1" roll.

Part No. 30 445 00 **\$4.50**

ENGRAVOLUBE-LUBRICANT

Prolongs life of cutters. Prevents burrs and guarantees a clean engraving on all metals or very soft plastic. Packed 6 plastic squeeze bottles to a carton.



(4 Fl. Oz. bottle)

30 460 00 per carton **\$12.00**

ALOXIDE

To blacken engraving on Anodized Aluminum

GRAVOXIDE

To blacken engraving on Lacquered Brass



Both solutions induce a chemical reaction that permanently blackens all engraved areas, creating a strong contrasting effect.



30 406 00 Aloxide 4 fl. oz.
30 461 00 Gravoxide 4 fl. oz.
3 to a carton **\$10.00**



ENGRAVER'S LAMP AND MAGNIFIER

Eliminates glare from overhead lighting. Insulated reflector, never heats up. The magnifier is easily attached to the lampshade and is ideal for close-up examination during the engraving process.

Part No. 30 295 00 Price: **\$25.00**

If purchased separately:

Engraver's Lamp 30 287 00 Price: **\$15.00**

Magnifier 30 294 00 Price: **\$15.00**

FOOT SWITCH

Can be used with all Engravographs.

Part No. 31 081 00 **\$12.00**



CUTTER HEAD WRENCH

For adjusting screws on cutter head.

Part No. 31 210 00 2 for **\$3.00**



CENTERING SCALES

30 339 30,	13 1/2" long,	for 5/8" slide
30 340 30,	18" long,	for 1 1/4" slide
30 341 30,	26" long,	for 5/8" and 1 1/4" slides
30 343 30,	22" long,	for 2 3/4" slides
30 344 30,	26" long,	for 2 3/4" slides
30 345 30,	36" long,	for 1 1/4" and 2 3/4" slides

\$3.00 each

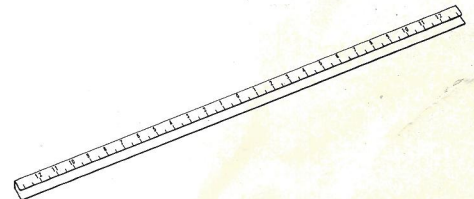

IMPORTANT:

When ordering parts please remember:

1. There is a minimum charge of \$15.00 per shipment. Save by **combining order** to meet minimum.
2. Use part numbers for quicker identification.
3. Give serial number of machine.

RESHARPENING SERVICE OF ROTATING CUTTERS

	High Speed Steel	Carbide Tipped
2 to 4 cutters	\$2.50 ea.	\$3.00 ea.
5 or more cutters	2.00 ea.	2.50 ea.

For customers who use New Hermes resharpening service only, rotating cutters, when worn due to multiple grinding, will be exchanged at the resharpening charge — however, cutters damaged beyond repair will not be resharpened. Grinding of parallel cutters add 50% to above prices.

HOW TO SELECT WIDTH OF CUTTER

The width of cut is determined by the height of character. For example, a ¼" high letter requires an approximate .030 width of cut—½" high letter requires approximate .060 width of cut. Below is a guide for the most suitable widths of cuts to use for characters of various heights:

Height of Character	⅛"	¼"	⅜"	½"	¾"	1"	1¼"	2"
Width of Cutter	.020	.030	.040	.060	.090	.125	.171	.250



These sizes are approximate and may vary with the style of type used.

Maximum width of cut obtainable with Models I-L, I-Lk, I-M	.125
" " " " " " ITF, ITF-K, ITX	.171
" " " " " " IRX-II	.250
" " " " " " VB	.500