

# Hermes safety saw<sup>®</sup>

the first accident proof saw PATENT PENDING  
with built in exhaust system

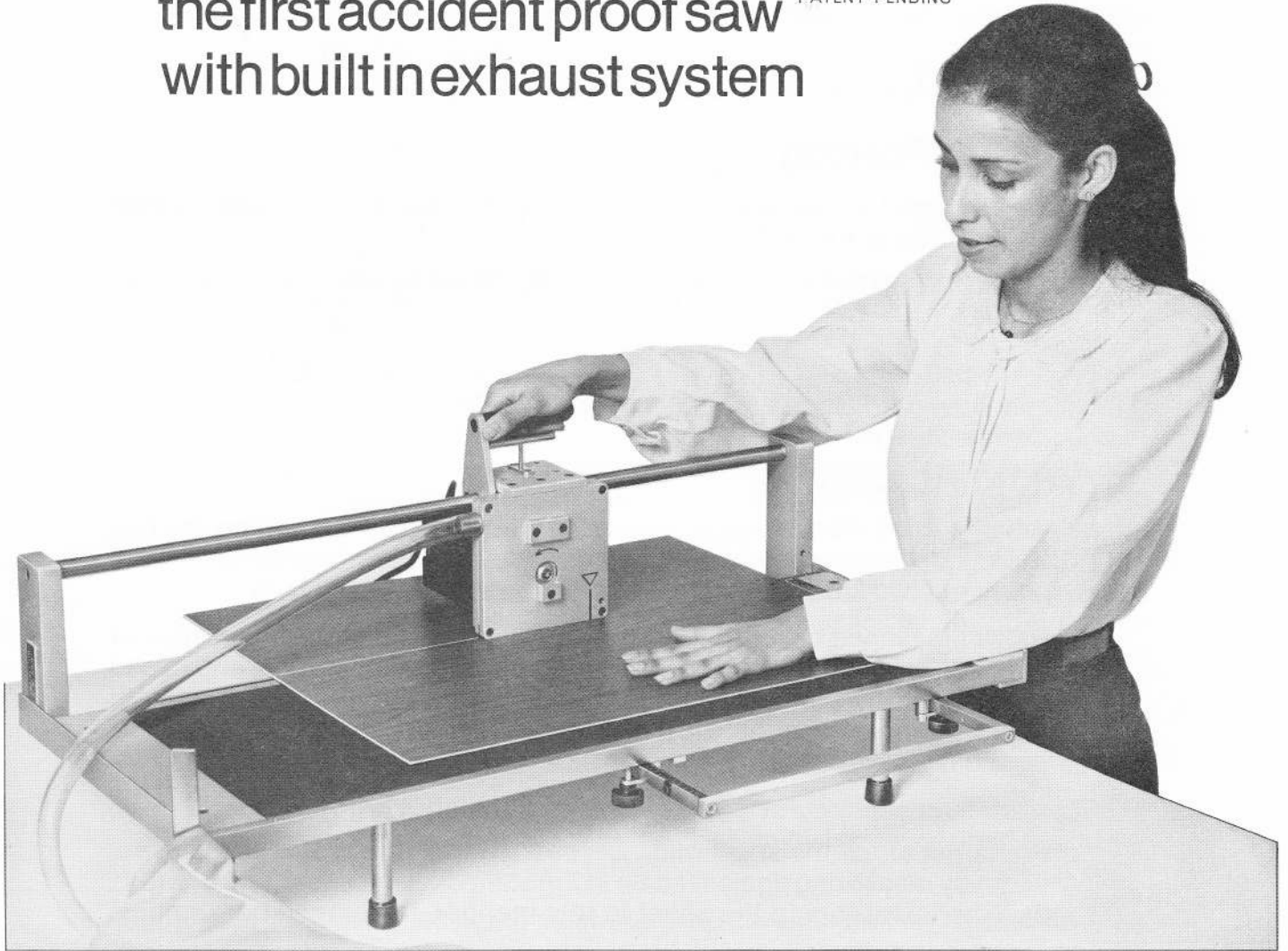

New Hermes is proud to introduce a machine tool for the sign and engraving industry which will be applauded by all insurance companies.

Hermes Safety Saw will cut 24" wide sheets of the following materials: Gravoply<sup>®</sup>, 2-Plex<sup>®</sup>, Cast Acrylics, Laminated Phenolics, Cardboard and Rubber.

Built in dust collector eliminates an additional exhaust system. The chips are automatically exhausted and deposited in a container.

# OPERATING PROCEDURES

## 1. Starting Position

Move saw head all the way to the rear, lifting the head so that it passes over the small step at the end of the slot.

**NOTE: Plastic sheets** up to 24" in width can be cut by any length. Up to 1/4" thickness.

## 2. Width Adjustment

- a) When cutting narrow strips, adjust the width stop #14 by setting the two sliding scales accurately. This adjustment is made by loosening or tightening the two knobs #11 on the underside of the table. (ILL. 4)
- b) Raise the hinged bar of the width stop #14 and position the sheet against the bar. This bar must be lowered during the cutting operation, and raised again to reposition the sheet for the next cut. Should the stop remain raised during cutting there is the danger of jamming which may result in a poor cut.
- c) Maximum adjustment this way is approximately 4<sup>3</sup>/<sub>4</sub>".
- d) For larger strips the sheet must be inserted from the motor side and set width by measuring against scale #12 mounted on the squaring bank (ILL. 3). When positioning the sheet in this manner, the hinged bar remains lowered.

**NOTE:**

In the event a standard sheet is not square it is advisable to square the edges by cutting a small strip approximately 1/8" wide.

**Warning:** All adjustments must be made with motor **OFF**.

## 3. Start Motor

**Illustration 3**

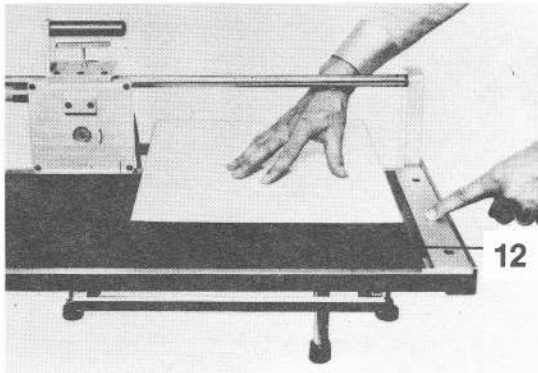

**Illustration 4**

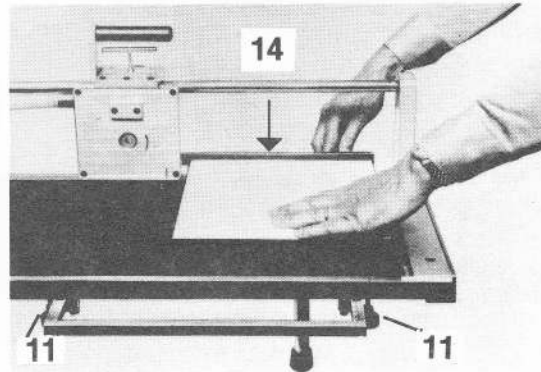

**Illustration 5**

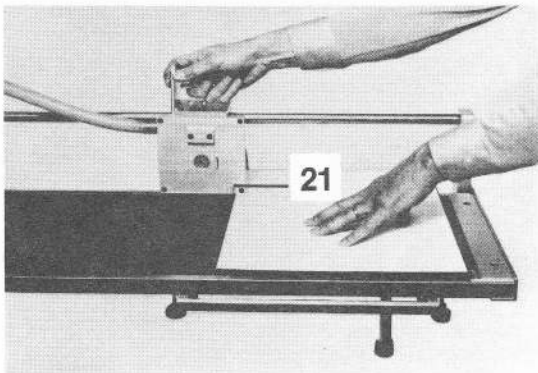

**Illustration 6**

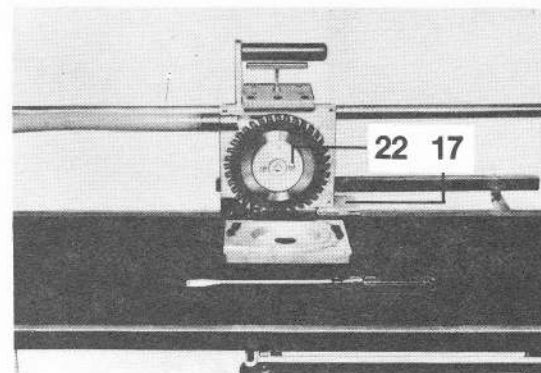

## 4. Cutting

- a) Grip the handle firmly with thumb on top and raise the lifting grip under the handle so that the saw housing can be placed over the sheet to be cut. There is an engraved line on the housing which indicates the start of the cut No. 21 (SEE ILL. 5)
- b) Lower the saw head so that it rests directly on the sheet. Pull the unit forward to the very end, then lift the saw head up and push it back to the starting position. Remove cut strip.  
**Do not lift saw head while cutting** — this will cause sheet to chip. Protective masking paper should be removed *after* the material has been cut to size.
- c) The saw blade rotates counter-clockwise. For best cut, place the sheet on the saw with engraving or masked side down. During cutting operation remember: Thick plates pull slowly — thin plates pull faster.

## 5. Changing Blade

- a) Before changing blade disconnect electrical cord from outlet. The saw head is moved to the middle of the table. Lift saw head and place a piece of material about 3/16" thick under the stationary portion of the blade housing (motor side.) (ILL. 6)
- b) Remove the four slotted screws from the cover until blade is exposed. Remove the retaining ring No. 22 (SEE ILL. 6). Remove blade. Before mounting new blade clean inside of housing thoroughly. Make sure that new blade is installed with teeth facing in the right direction. The rotation is counter-clockwise. Reinstall ring then cover. Before replacing cover put a thin layer of grease on inside face that contacts the housing so that housing will remain airtight.
- c) For proper maintenance the blade must be cleaned after each 24 hours of cutting time. This will prevent the blade from getting dull and insure a clean cut each time.

Use a small bristle brush and resin cleaner solvent making sure to remove the plastic that adheres to both sides and front of each saw tooth.

**SAW BLADE** — Carbide Teeth # .060" thick  
Diameter # 4 5/8" dia.  
Number of Teeth per inch # 2½

# ASSEMBLY AND INSTALLATION PROCEDURES

1. Remove Hermes Safety Saw unit from carton. Make sure that the legs in small box with parts are also removed.
2. Install all four legs (No. 20) onto the underside of the saw table frame.
3. Place unit on a flat table or workbench and adjust legs until the unit is level and there is no rocking motion corner to corner.
4. Clean unit free of all packaging dust. Using an oil dampened rag, wipe slide rod (No. 18) clean.
- 5. Remove locking bolt (No. 13) used for shipping only.**
6. Remove grip handle (No. 1) from shipping position and install with two screws provided as shown in Illustration #1.
7. Slide saw head up and down by using the lifting grip (No. 2) to test ease of motion.
8. In the up position, slide the saw unit along the entire length of slide rod (No. 18).
9. Install sack holder angle bracket in place with knob (No. 9). Using the strap on the outside of sack install onto angle bracket. Place plastic hose from the saw head into open end of dust collecting sack and in front of vertical member of the angle bracket. Allow enough hose outside of the bag so that the saw head can move freely through the full stroke. Position safety saw at the edge of a table or stand so that the full length of the dust collecting sack hangs free. The opening in the dust collecting sack should allow hose to move in and out freely. If dust particles are emitted from the dust collecting sack while cutting, place two paper clips, one on each side of the hose, to partially close the opening.  
Do not tape opening of sack closed.
10. Install one end of the hose (No. 6) onto nipple (No. 5) on saw head.
11. Insert the other end of the hose into the dust collecting sack. Make sure there is enough slack in the hose so that the saw head can travel the full length of the saw table.
12. Place the three prong electrical plug from the motor line cord into any 115 volt AC receptacle. Make sure there is enough slack in the line cord so as to not interfere with the full travel of the saw head.

## Maintenance

In order to insure unobstructed movement of the saw head the slide rod should be lubricated and cleaned with an oil dampened rag at the end of each day's use. Every two weeks it is advisable to check the motor brushes for wear.

Periodic cleaning of the saw blade is necessary to produce a consistently clean cut on the Hermes Safety Saw. For detailed instructions see Item 5, changing blade. If after cleaning the blade as recommended a clean cut cannot be achieved return the saw blade to New Hermes for resharpening. The purchase of a spare blade is recommended to avoid interruption of production.

# INSTRUCTIONS

## HERMES SAFETY SAW NO. 25-300-00

1. Grip Handle
2. Lifting Grip
3. Removable Blade Cover
4. Holder for Lubrication Bottle
5. Nipple for Hose
6. Hose
7. Dust Collecting Sack
8. Rubber Ring for Clamping Sack
9. Fastening Knob for Sack Holder
10. Scales for Setting Adjustable Stop
11. Knob for Clamping Stop
12. Scale for Cutting Larger Plates when inserted from Motorside
13. Locking Bolt—only used for shipping
14. Width Stop—Can be lowered out of the way
15. Motor Switch
16. Motor Brushes
17. Saw Head
18. Slide Rod
19. Guide Groove
20. Legs

Illustration 1

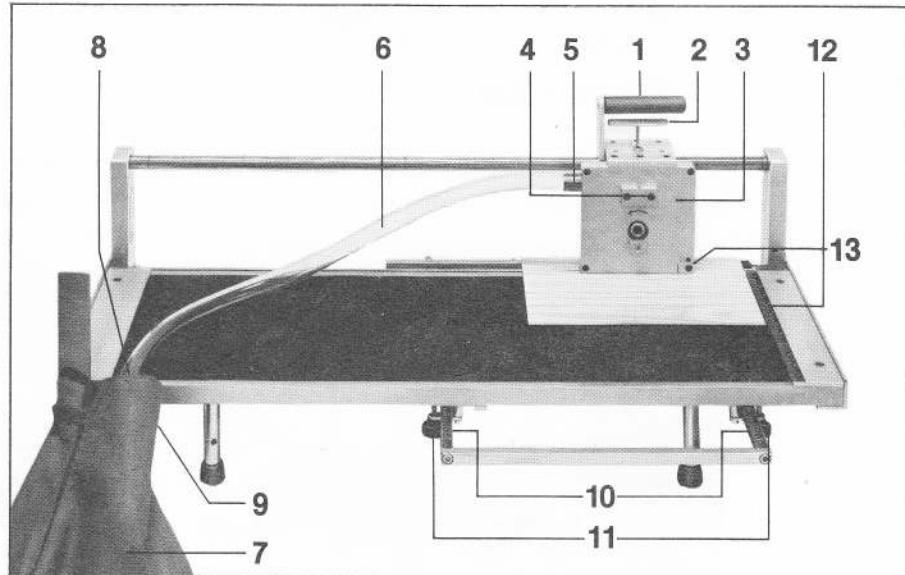
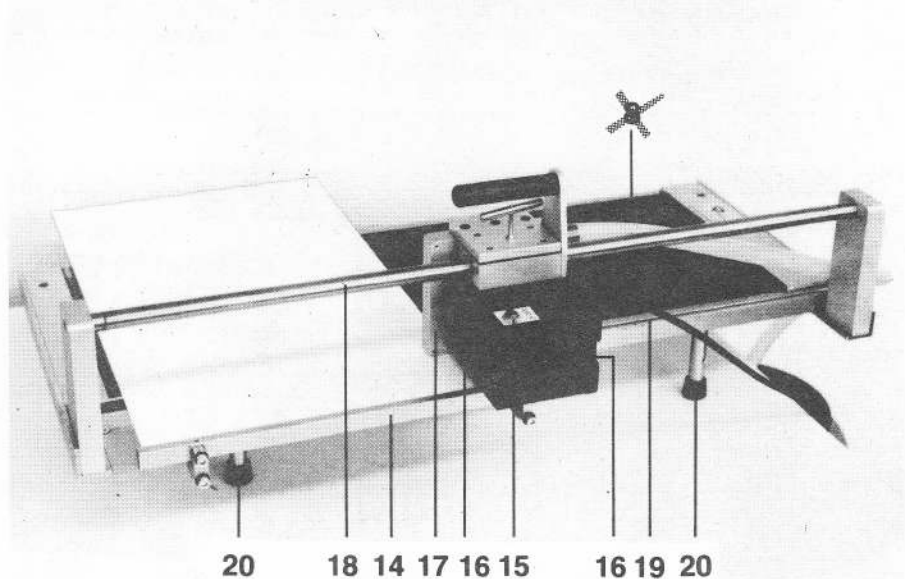

Illustration 2



**new**  
**Hermes**  
incorporated

20 Cooper Square, New York, N.Y. 10003

Tel. (212) 777-3080

**MIDWEST**

3642 West 128 Place  
Alsip (Chicago), Ill. 60658  
(312) 371-3744

**SOUTHEAST**

2443 Park Central Blvd.  
Decatur, Georgia 30035  
(404) 981-2562

**SOUTHWEST**

12243 E. Northwest Hwy.  
Dallas, Texas 75228  
(214) 328-9835

**WEST COAST**

11711 Monarch Street  
Garden Grove, Calif. 92641  
(714) 898-9265

**FLORIDA**

5680 N.W. 161 Street  
Hialeah, Florida 33014  
(305) 625-1751

**CANADA**

1135 Meyerside Dr.  
Mississauga, Ont. L5T 1J6  
(416) 677-2224  
323 Benjamin Hudon St.  
Montreal, Quebec, H4N 1J1  
(514) 334-1780